

WARNINGS AND PRECAUTIONS

- WARNING: To prevent fire or shock hazards, do not expose this unit to rain or moisture.
- WARNING: Do not place this unit directly onto furniture surfaces with any type of soft, porous, or sensitive finish. As with any rubber compound made with oils, the feet could cause marks or staining where the feet reside. We recommend using a protective barrier such as a cloth or a piece of glass between the unit and the surface to reduce the risk of damage and/or staining.
- WARNING : Where the mains plug or appliance coupler is used as the disconnect device, such disconnect device shall remain readily operable.
- Batteries should be recycled or disposed of as per state and local guidelines.

Note : This device uses an internal rechargeable lithium-ion battery that should last the lifetime of the device. If you suspect your battery may be dead after several attempts to charge, please contact 1-888-999-4215 for support.

Never disassemble the unit or attempt to remove the battery as that could cause leakage of an electrolytic substance.

FCC WARNINGS

- Warning: Changes or modifications to this unit not expressly approved by the party responsible for compliance could void the user's authority to operate the equipment.

NOTE: This equipment has been tested and found to comply with the limits for a Class B digital device, pursuant to Part 15 of the FCC Rules. These limits are designed to provide reasonable protection against harmful interference in a residential installation. This equipment generates, uses, and can radiate radio frequency energy and, if not installed and used in accordance with the instructions, may cause harmful interference to radio communications. However, there is no guarantee that interference will not occur in a particular installation. If this equipment does cause harmful interference to radio or television reception, which can be determined by turning the equipment off and on, the user is encouraged to try to correct the interference by one or more of the following measures:

- Reorient or relocate the receiving antenna.
- Increase the separation between the equipment and receiver.
- Connect the equipment into an outlet on a circuit different from that to which the receiver is connected.
- Consult the dealer or an experienced radio/TV technician for help.

FEATURES

- Built-in microphone
- Driver: 40mm
- Micro-USB port for battery recharge
- DC battery power: built-in rechargeable lithium ion battery
- Battery life:
approx. 3-4 hours (reactive)
approx. 50 min. (constant)

NOTE:

THE INTERNAL BATTERY ONLY POWERS THE LED LIGHTS. AUDIO POWER FOR THE HEADPHONES COMES THROUGH THE HEADPHONE JACK OF A CONNECTED DEVICE. THE HEADPHONES WILL STILL PLAY AUDIO, EVEN IF THE BATTERY IS COMPLETELY DRAINED.

INCLUDES

- Micro-USB to USB cable

CONTROLS

Lights/Play/Pause/Answer

Press and hold for 3 seconds for reactive mode.
Press and hold for 3 seconds to turn the lights off.
Press and hold for 5 seconds for constant mode.
Press and hold for 3 seconds to turn the lights off.
Press to play or pause an audio track.
Press to answer an incoming call.

NOTE: It is not possible to switch the lights directly from reactive to constant mode, they must be powered off first.

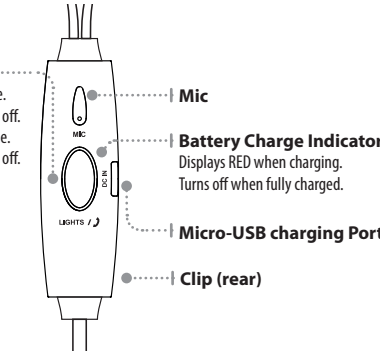

BATTERY POWER

To charge the earbuds, connect the included **Micro-USB to USB** cable to a **USB port** on a powered computer, or other USB power source. Charge fully before use.

When charging, the unit will display a red indicator light.

When the earbuds are fully charged, the red indicator light will turn off.

NOTE:

For safety reasons, please do not use the earbuds while they are charging.

INTERNATIONAL SUPPORT

To download this User's Guide in English, Spanish, or French, or to get answers to frequently asked questions, visit the support section at:

www.iLiveElectronics.com

Para descargar este Manual del Usuario en inglés, español y francés, o para obtener respuestas a preguntas frecuentes, visite la sección de apoyo en:

www.iLiveElectronics.com

Pour télécharger ce guide de l'utilisateur en anglais, espagnol ou français, ou pour obtenir des réponses à des questions fréquemment posées, consultez la rubrique d'assistance sur:

www.iLiveElectronics.com

CONTACT INFORMATION

Website: www.iLiveElectronics.com

Email Support: prodinfo@dpiinc.com

Email Parts: partsinfo@dpiinc.com

Phone Support: 1-888-999-4215

WARRANTY

For Warranty Information and the most up-to-date version of this User's Guide, go to: **www.iLiveElectronics.com**



*Protect for Today
Sustain for Tomorrow*



Glowing Headphones

User's Guide for Model No. IAHL75 v1346-02

